

Self-operated Pressure Regulators



Excess Pressure Valve with pilot valve Type 2335



Fig. 1 · Type 2335 Excess Pressure Valve

Mounting and Operating Instructions

EB 2552-2 EN

Edition November 2011



Contents	Page
1	Design and principle of operation 4
2	Installation 7
2.1	Installation instructions 7
2.2	Strainer. 8
2.3	Shut-off valve 8
2.4	Pressure gauge 8
3	Operation 8
3.1	Start-up 8
3.1.1	Steam regulation 9
3.2	Set point adjustment. 9
3.3	Decommissioning 9
4	Maintenance · Troubleshooting 10
5	Nameplate 14
6	Customer service 14
7	Technical data 15
8	Dimensions 16

Definitions of the signal words used in these instructions

CAUTION!

indicates a hazardous situation which, if not avoided, may result in minor or moderate injury.

NOTICE

indicates a property damage message.

Note:

Supplementary explanations, information and tips

General safety instructions

- ▶ *The regulators must be installed, started up and serviced by fully trained and qualified personnel only, observing the accepted industry codes and practices. Make sure employees or third persons are not exposed to any danger. All safety instructions and warnings in these instructions, particularly those concerning installation, start-up and maintenance, must be observed.*
- ▶ *The regulator complies with the requirements of the European Pressure Equipment Directive 97/23/EC. The declaration of conformity issued for a valve bearing the CE marking includes information on the applied conformity assessment procedure.
The declaration of conformity can be provided on request.*
- ▶ *For appropriate operation, make sure that the regulator is only used in applications where the operating pressure and temperatures do not exceed the operating values based on the sizing data submitted in the order.*
- ▶ *Note that the manufacturer does not assume any responsibility for damage caused by external forces or any other external factors.*
- ▶ *Any hazards which could be caused in the regulator by the process medium or operating pressure are to be prevented by means of appropriate measures.*
- ▶ *Proper shipping and appropriate storage are assumed.*

1 Design and principle of operation

The medium flows through the globe valve (1) as indicated by the arrow. The position of the valve plug determines the flow rate across the area released between the plug (3) and seat (2). The travel position of the pilot valve (5) determines the pressure conditions across the valve.

The force created by the upstream pressure p_1 acting on the plug surface and the opposing forces created by the control pressure p_s and the positioning spring (3.1) are compared.

In the **Type 2335 Excess Pressure Valve**, a rise in upstream pressure p_1 causes the pilot valve and the main valve to open.

Together with the pilot valve, the Venturi nozzle (6) or fixed restrictor (10) for the steam version create the control pressure p_s .

If the pilot valve remains closed, the valve is fully balanced. The upstream pressure p_1 counterbalances the control pressure p_s ($p_s = p_1$) acting on the outside of the balancing bellows (4) (or on the balancing diaphragm in the case of valves balanced by a diaphragm) between the pilot valve and the fixed restrictor (10) or Venturi nozzle (6).

The spring located below the plug closes the valve.

By opening the pilot valve, the control pressure p_s and the differential pressure across the balancing bellows or diaphragm increases as a result. The force acting on the plug surface opposes the force of the positioning spring and opens the valve.

To ensure proper functioning, the minimum differential pressure Δp_{\min} listed in Table 1 must be available as specified depending on the field of application.

The regulator version for **steam** is only available with valves balanced by a bellows. This version has an equalizing tank (10) already fitted in the control line. The needle valve (9) is open and lead-sealed.

Prior to start-up, the equalizing tank must be filled with water until it flows over the top of the filler neck.

Table 1 · Minimum differential pressure Δp_{\min}

Nominal size		DN 125	DN 150	DN 200	DN 250	DN 300	DN 400
Minimum differential pressure Δp_{\min}	Valve balanced by a bellows for steam	1.2 bar	1 bar	0.8 bar	0.8 bar	–	–
	Valve balanced by a bellows for air/water	0.8 bar	0.9 bar	0.6 bar	0.6 bar	–	–
	Valve balanced by a diaphragm	0.45 bar	0.45 bar	0.4 bar	0.4 bar	0.3 bar	0.3 bar

Type 2335 Excess Pressure Valve · Type 2422 Valve balanced by a bellows
 DN 125 to 250

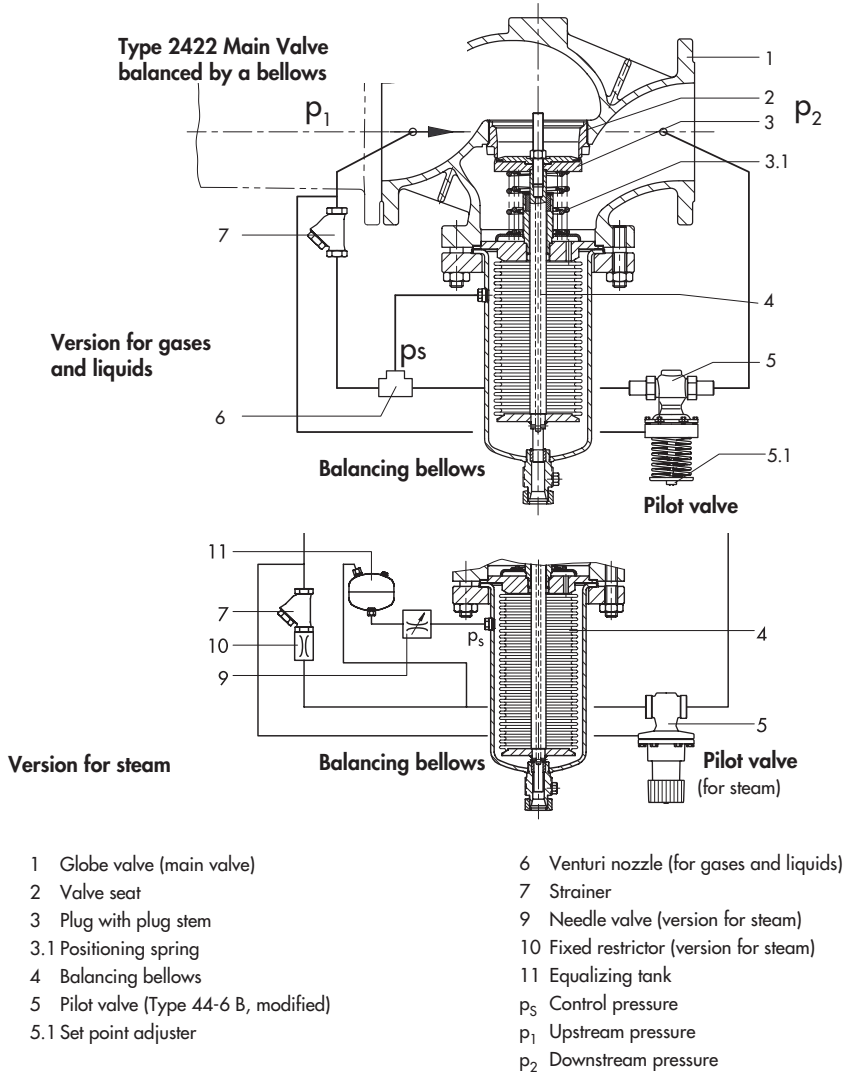
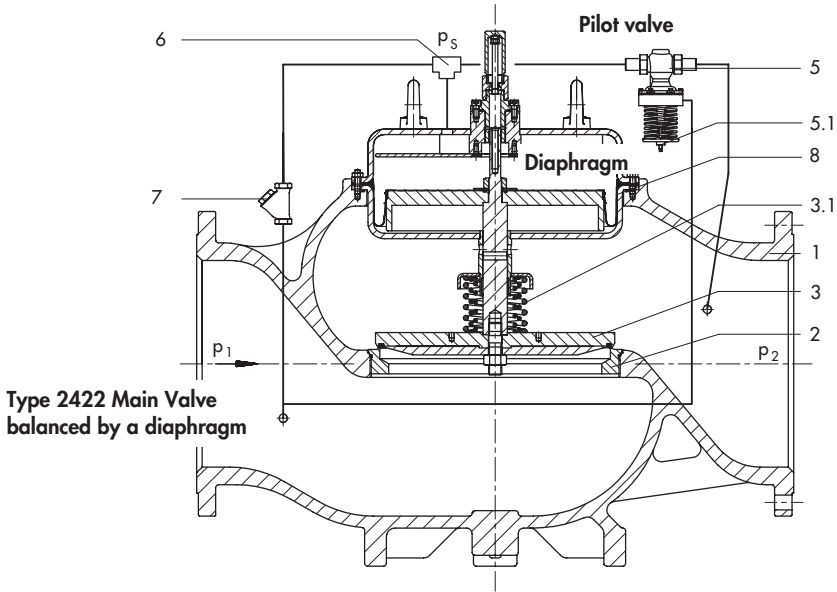

Fig. 2 · Functional drawing of valve **balanced by a bellows**

Type 2335 Excess Pressure Valve · Type 2422 Valve balanced by a diaphragm
 DN 125 to 400



**Type 2422 Main Valve
 balanced by a diaphragm**

- 1 Valve body
- 2 Valve seat
- 3 Plug with plug stem
- 3.1 Positioning spring
- 5 Pilot valve (Type 44-7, modified)
- 6 Venturi nozzle
- 7 Strainer
- 8 Balancing diaphragm

- p_s Control pressure
- p_1 Upstream pressure
- p_2 Downstream pressure

Fig. 3 · Functional drawing of valve **balanced by a diaphragm**

2 Installation

On selecting the position of installation, make sure that the regulator can still be easily accessed after completion of the plant.

Note: Flush the pipeline thoroughly prior to installing the regulator otherwise sealing particles, welding spatter or other impurities carried along by the process medium could impair the proper functioning of the valve.

On selecting the position of installation, make sure that the regulator is installed at a distance of at least six times the nominal size (DN) away from pipe fittings or instruments that cause flow turbulence (e.g. pipe bends, manifolds, pressure measuring points or other valves). They can change the flow conditions which may lead to an instable control process especially in applications with gases, air or steam.

NOTICE

Do not insulate the pilot valve when the medium temperature exceeds 80 °C.

Protect the regulator against frost when controlling freezing media.

Prior to removing the regulator, make sure the relevant section of the plant has been depressurized and drained.

2.1 Installation instructions

Install the regulator with the ready-mounted control lines in the horizontal pipeline.

Note: When the regulator is installed in the pipeline, the side of the valve on which the hooked-up pilot valve is mounted differs depending on whether the valve is balanced by a bellows or a diaphragm.

- **Valve balanced by a bellows**
Bellows suspended downwards.
- **Valve balanced by a diaphragm**
Balancing diaphragm on top.

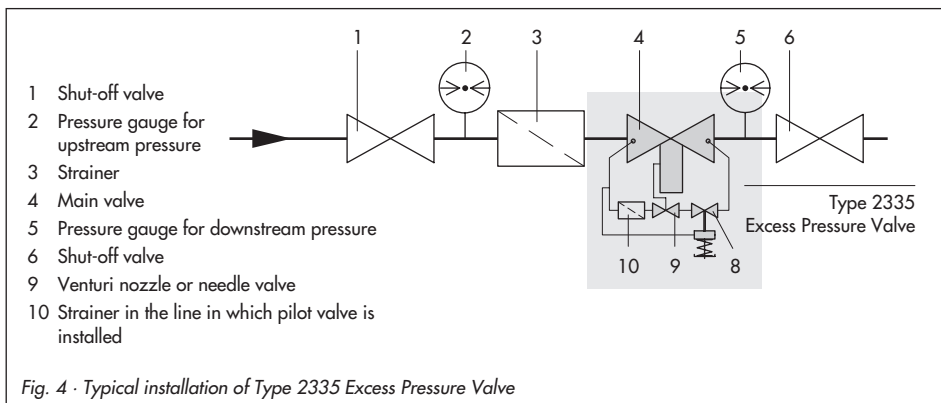

The regulator must be installed free of stress. If necessary, support the piping near the connections. However, do not attach supports to the valve or actuator.

Make sure the medium flows through the valve in the direction indicated by the arrow.

2.2 Strainer

A strainer installed in the flow pipe prevents foreign matter and dirt particles in the medium from entering the regulator. The SAMSON product range includes the Type 2 N/2 NI Strainer (refer to Data Sheet T 1015 EN).

- Make sure the direction of medium flow corresponds with the direction indicated by the arrow on the strainer.
- The filter element must be suspended downwards or be located at the side for applications with steam.
- Remember to leave enough space to remove it.

2.3 Shut-off valve

We recommend installing a hand-operated shut-off valve both upstream of the strainer and at the outlet of the return flow pipe (Fig. 4). This allows the plant to be shut down for cleaning and maintenance, and when the plant is not used for longer periods of time.

2.4 Pressure gauge

To monitor the pressures in the plant, install a pressure gauge both upstream and downstream of the regulator.

3 Operation

3.1 Start-up

First start up the regulator after mounting all the components, e.g. valve and control line. Make sure the control lines (and needle valves) are open and correctly connected before start-up.

NOTICE

When testing the pressure of the plant when the regulator is already installed, the test pressure must not damage the balancing bellows or the balancing diaphragm.

The pressure must not exceed the maximum permissible pressure of the regulator and plant.

Rinsing the plant · After filling the plant, first completely open the consumers. Adjust the maximum set point. Rinse out the pipeline at full flow rate for several minutes. Check the installed strainer (e.g. by measuring the pressure drop) afterwards. Clean the strainer, if necessary.

- ▶ Fill the plant **slowly**. Make sure that the pressures upstream and downstream of the regulator rise at the same time to prevent the balancing bellows/diaphragm from being damaged.
- ▶ Open all the valves on the consumer side. Gradually open the shut-off valves starting on the flow side in small steps (wait one minute each time before continuing).

3.1.1 Steam regulation

Observe the following instructions when the pressure reducing valve is used to regulate steam:

- ▶ To prevent water hammering, all pipes conveying the process medium must be completely drained and dried before start-up.
- ▶ Prior to start-up, fill the equalizing tank with water.
- ▶ Fill the plant **slowly**. Allow enough time for the pipelines and valves to warm up.
- ▶ Make sure that air can be vented and condensate can be drained properly from the plant. Install steam traps and air vents for steam-operated systems at suitable locations (e.g. SAMSON Type 13 E and Type 3).

3.2 Set point adjustment

Adjust the set point for upstream pressure at the set point adjuster of the pilot valve (5.1) after all the consumers in the plant have been opened.

After the upstream pressure has reached the adjusted set point, the pilot valve opens, causing the main valve to open as well.

- ▶ Turn the set point adjuster clockwise (↻) to increase the upstream pressure
- ▶ Turn the set point adjuster counterclockwise (↺) to reduce the upstream pressure

The pressure gauge mounted on the upstream side allows the set point to be monitored.

First turn the set point adjuster clockwise (↻) to the maximum set point.

Wait until the excess pressure valve starts to regulate and slowly turn the set point adjuster counterclockwise (↺) to adjust the exact set point.

***Note:** Start by turning the set point adjuster by one turn at a time and wait until the upstream pressure reaches the set point. After that, you can adjust the set point by making larger changes. After start-up and set point adjustment, avoid fast changes in pressure.*

3.3 Decommissioning

Depressurize the plant. Close the shut-off valves starting from the flow side (high-pressure line).

4 Maintenance · Troubleshooting

The regulators are maintenance free. Nevertheless, they are subject to natural wear, particularly at the seat, plug and bellows/diaphragm.

Depending on the operating conditions, the regulator needs to be checked at regular intervals to avoid possible malfunctions.

CAUTION!

On performing any work on the regulator, make sure the relevant section of the pipeline is depressurized and, depending on the process medium, drained as well.

We recommend to remove the valve from the pipeline.

For high temperatures, allow the regulator to cool down to ambient temperature before starting any work on it.

Interrupt or shut off the control line to avoid any hazards which could be caused by moving parts.

As valves are not free of cavities, remember that residual process medium might still be contained in the valve.

Details on malfunctions and the recommended action can be found in the **Table 2 · Troubleshooting**.

The listed examples of malfunctions are caused by mechanical faults in the main valve or pilot valve as well as incorrect regulator sizing.

In the simplest case, the functioning can be restored following the recommended action. To repair the pilot valve, read the operating instructions for the regulator (pilot valve). As in

many cases, special tools are required, we advise you to contact SAMSON to find out how to proceed to repair the regulator or replace a component.

Exceptional operating and installation conditions can lead to changed situations that may affect the control response and lead to malfunctions. In such cases, check the installation conditions, process medium, temperature and pressure conditions. A thorough analysis may require the on-site assistance of SAMSON After-sales Service.

The table is not intended to be exhaustive as there are diverse reasons for malfunctions.

Table 2 • Troubleshooting

Malfunction	Possible reason	Recommended action	Comments
Malfunction only occurs when the consumer is closed or during low load:			
Upstream pressure does not reach the adjusted set point	Pilot valve · Shut-off impaired (leakage between seat and plug)	Remove valve from the pipeline and clean seat and plug. Replace plug, if necessary. Otherwise, return regulator to SAMSON for repair.	Install a shut-off valve instead of the pilot valve. If the main valve closes when the shut-off valve is closed, the pilot valve has caused the malfunction.
	Main valve · Shut-off impaired (leakage between seat and plug)	Remove valve from the pipeline and clean seat and plug. Replace plug, if necessary. Otherwise, return regulator to SAMSON for repair.	
Malfunction occurs when the consumer is open or at maximum load:			
Upstream pressure is much higher than the adjusted set point	The pilot valve does not function. Balancing bellows/diaphragm defective Medium leaks from the actuator.	Replace the defective component.	Install a shut-off valve instead of the pilot valve. If the main valve opens when the shut-off valve is opened, the pilot valve has caused the malfunction.
	Pilot valve seized up	Clean the pilot valve. Apply grease to feed-through bushing, if necessary. Replace defective parts.	
	Main valve seized up	Clean the main valve	Install a shut-off valve instead of the pilot valve. If the main valve does not open when the shut-off valve is opened, the main valve has caused the malfunction.
	Balancing bellows/diaphragm of main valve defective	Replace bellows/diaphragm.	Install a shut-off valve instead of the pilot valve. If the main valve does not open when the shut-off valve is opened, the main valve has caused the malfunction. Particularly in steam applications, water hammering can damage the bellows. Therefore, make sure that no water or condensate is present in the pipeline before start-up.

Table 2 (continued) · Troubleshooting

Malfunction	Possible reason	Recommended action	Comments
The upstream pressure set point is not reached	Strainer in the line in which the pilot valve is installed is clogged	Clean strainer.	
	The required minimum differential pressure to operate the regulator is not available	Increase upstream pressure or reduce downstream pressure	
	Set point range of the pilot valve is too low	Convert or replace pilot valve.	
	Main valve seized up	Clean main valve.	Install a shut-off valve instead of the pilot valve. If the main valve does not open when the shut-off valve is opened, the main valve has caused the malfunction.
	Pilot valve seized up	Clean pilot valve. Clean internal control line used to tap the downstream pressure.	Install a shut-off valve instead of the pilot valve. If the main valve does not open when the shut-off valve is opened, the main valve has caused the malfunction.
	Needle valve installed between fixed restrictor and main valve is jammed or closed.	Clean the needle valve. Check setting (open).	
	Main valve is sized to be too small (K_{VS}/C_V)	Resize the valve. Replace main valve.	
Regulator's reaction is sluggish	Strainer in the line in which the pilot valve is installed is clogged	Clean strainer.	
	Inside the pilot valve is clogged up, impairing the flow through the valve	Clean inside the pilot valve.	
	Needle valve (for steam) installed between fixed restrictor and main valve is jammed or closed.	Clean needle valve. Check setting (open).	

Table 2 (continued) · Troubleshooting

Malfunction	Possible reason	Recommended action	Comments
Control loop hunts	K_{VS}/C_V of pilot valve too large (after valve has been replaced).	Install pilot valve with suitable K_{VS}/C_V coefficient.	
	Needle valve (steam) in the line in which the pilot valve is installed has been removed.	Order needle valve from SAMSON, specifying exact details on the pilot valve.	
	The flow conditions in the plant at the location where the regulator is installed are not suitable for the regulator.	Install the regulator at a distance of at least six times the nominal size (DN) away from pipe fittings or instruments that cause flow turbulence (e.g. pipe bends, manifolds, pressure measuring points or other valves). They can change the flow conditions which may lead to an instable control process especially in applications with gases, air or steam.	If this is the case, send a sketch of the plant to SAMSON for a thorough analysis.
	K_{VS}/C_V of main valve too large	Resize the main valve. Replace the valve or convert it to achieve a smaller K_{VS}/C_V coefficient.	

5 Nameplate

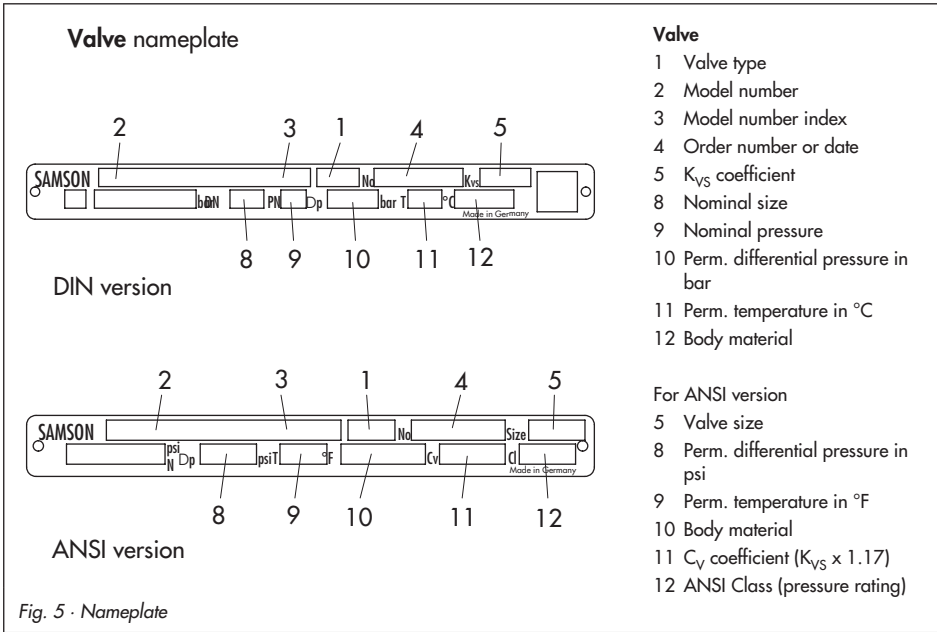

6 Customer service

Should any malfunctions or any defect occur, SAMSON's After-Sales Service is prepared to help you on site.

You can also send the defective regulator directly to your local SAMSON representative for repair. Addresses of SAMSON subsidiaries, agencies and service centers are listed in the product catalogs and in the Internet at www.samson.de.

To allow SAMSON to find the fault and to have an idea of the installation situation, specify the following details (refer to the nameplate):

- ▶ Type and nominal size of the valve
- ▶ Order and model numbers
- ▶ Upstream and downstream pressures
- ▶ Flow rate in m^3/h
- ▶ Has a strainer been installed?
- ▶ Installation drawing

7 Technical data

Table 3 · Technical data · All pressures in bar (gauge)

Type 2422 Valve balanced by a bellows · Suitable for liquids, gases and vapors

Nominal size	DN 125	DN 150	DN 200	DN 250	DN 300	DN 400
Nominal pressure	PN 16 to 40					
K_{VS} coefficient	200	360	520 ¹⁾	620 ¹⁾		
$K_{VS I}$ (with flow divider St I)	150	270	400 ¹⁾	500 ¹⁾		
$K_{VS III}$ (with flow divider St III)	100	180	260 ¹⁾	310 ¹⁾		
z value	0.35	0.3	0.3			
Minimum differential pressure Δp_{min} for vapors for gases and liquids	1.2 bar 0.8 bar	1.0 bar 0.9 bar	0.8 bar ¹⁾ 0.6 bar ¹⁾			
Maximum differential pressure Δp_{max}	16 bar	12 bar	10 bar ¹⁾			
Leakage class acc. to IEC 60534-4	≤ 0.05 % of K_{VS} coefficient ²⁾					
Max. perm. temperature (depending on pilot valve)	Type 44-7: 150 °C · Type M 44-7: 130 °C · Type 44-6 B: 200 °C Type 41-73: 350 °C					
Set point ranges in bar, continuously adjustable at the pilot valve	Type 44-7: 1 to 4, 2 to 4.4, 2.4 to 6.6, 6 to 11 Type M 44-7: 1 to 5, 4 to 12 Type 44-6 B: 1 to 4, 2 to 6, 4 to 10, 8 to 20 bar Type 41-73: 0.8 to 2.5, 2 to 5, 4.5 to 10, 8 to 16, 10 to 22, 20 to 28					

¹⁾ Version with reduced K_{VS} coefficient possible. Technical data same as for DN 150

²⁾ ≤ 0.1 % of K_{VS} coefficient with metal-seated plug

Type 2422 Valve balanced by a bellows · Suitable for liquids and gases

Nominal size	DN 125	DN 150	DN 200	DN 250	DN 300	DN 400
Nominal pressure	PN 16 to 40					
K_{VS} coefficient	250	380	650 ¹⁾	800 ¹⁾	1250	2000
z value	0.35		0.3 ¹⁾		0.2	
Minimum differential pressure Δp_{min}	0.45 bar		0.4 bar ¹⁾			0.3 bar
Maximum differential pressure Δp_{max}	12 bar		10 bar ¹⁾			6 bar
Leakage class acc. to IEC 60534-4	≤ 0.01 % of K_{VS} coefficient					
Max. perm. temperature (depending on pilot valve)	Type 44-7: 150 °C · Type 44-6 B: 150 °C · Type M 44-7: 130 °C Type 41-73: 150 °C · Steam pressure regulator as special version on request					
Set point ranges in bar, continuously adjustable at the pilot valve	Type 44-7: 1 to 4, 2 to 4.4; 2.4 to 6.6; 6 to 11 · Type M 44-7: 1 to 5, 4 to 12 · Type 44-6 B: 1 to 4, 2 to 6, 4 to 10, 8 to 20 Type 41-73: 0.8 to 2.5, 2 to 5, 4.5 to 10, 8 to 16, 10 to 22, 20 to 28					

¹⁾ Version with reduced K_{VS} coefficient possible. Technical data same as for DN 150

8 Dimensions

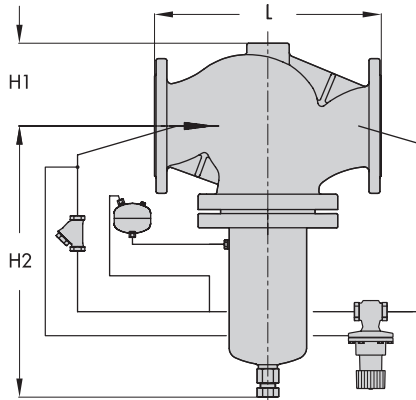

Type 2422 Valve · DN 125 to 250

The drawing shows the version for steam regulation

Nominal size	DN 125	DN 150	DN 200	DN 250
Length L	400 mm	480 mm	600 mm	730 mm
Height H1	145 mm	175 mm	235 mm	260 mm
Height H2	460 mm	590 mm	730 mm	
Weight ¹⁾ (PN 16 with Type 50 ES as pilot valve)	75 kg	118 kg	260 kg	305 kg

¹⁾ +10 % for cast steel 1.0619/PN 25 and spheroidal graphite iron EN-JS1049/PN 25

Fig. 6 · Dimensions and weights · Type 2422 Valve **balanced by a bellows**

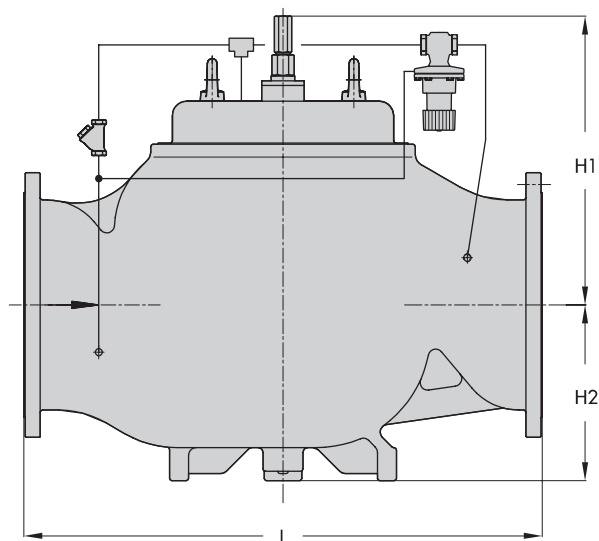

Type 2422 Valve · DN 125 to 400

Nominal size	DN 125	DN 150	DN 200	DN 250	DN 300	DN 400
Length L	400 mm	480 mm	600 mm	730 mm	850 mm	1100 mm
Height H1	285 mm	310 mm	380 mm		510 mm	610 mm
Height H2	145 mm	175 mm	260 mm		290 mm	390 mm
Weight ¹⁾ (PN 16 with Type 50 ES as pilot valve)	50 kg	70 kg	210 kg	220 kg	315 kg	625 kg

¹⁾ +10 % for cast steel 1.0619/PN 25 and spheroidal graphite iron EN-JS1049/PN 25

 Fig. 7 · Dimensions and weights · Type 2422 Valve **balanced by a diaphragm**



SAMSON AG · MESS- UND REGELTECHNIK
Weismüllerstraße 3 · 60314 Frankfurt am Main · Germany
Phone: +49 69 4009-0 · Fax: +49 69 4009-1507
Internet: <http://www.samson.de>

EB 2552-2 EN

S/Z 2011-12